

# TFSK/TFSR roof fans

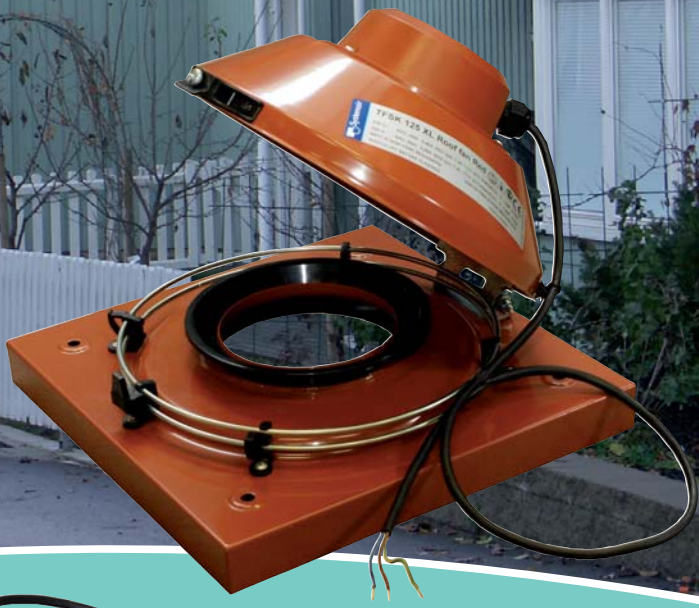

**TFSK/TFSR**  
Roof fans with  
swing-out function

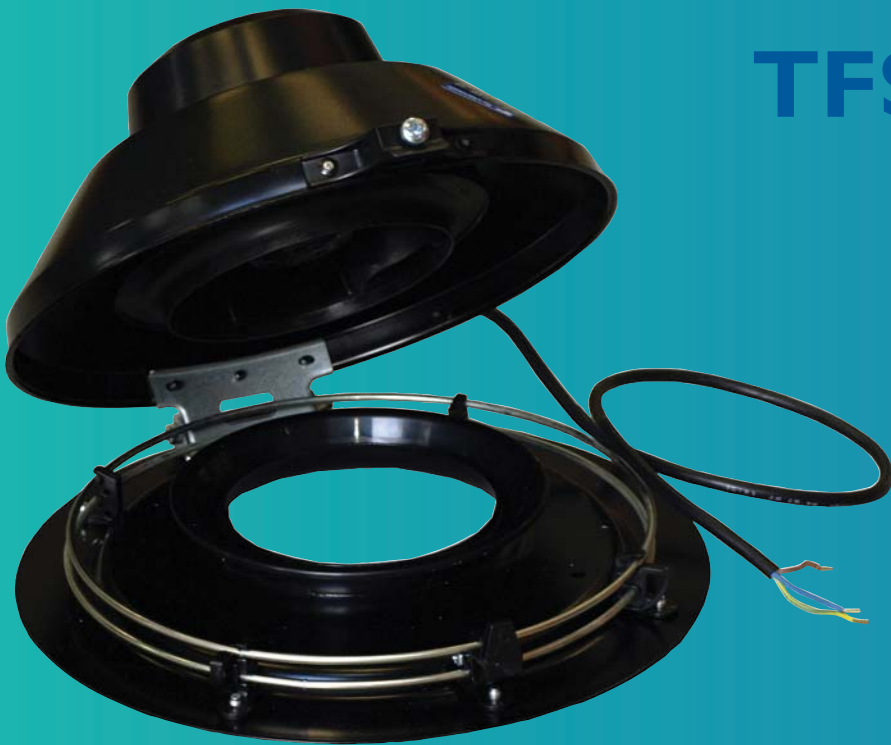



## TFSR/TFSK

The TFSR and TFSK roof mounted fans are intended for use as extract fans in smaller premises such as self contained flats and apartments as well as storage areas, smaller work-rooms etc.

The TFSR/TFSK is easy to install and use. The isolation switch is integrated and there are several alternative roof curbs available as accessories. The tilting mechanism simplifies cleaning and maintenance.

The fans can be speed-controlled via a 5-step transformer or a stepless thyristor, both available as accessories. To protect the motors from overheating, the fans have an integrated thermal contact with automatic reset.

The TFSR and TFSK are manufactured from powder-coated galvanised sheet steel in standard colours black or brick red (silver grey available on special request). The TFSR comes with circular connection whilst the TFSK is provided with a square connection.

The horizontal discharge creates smaller internal pressure losses and prevents accumulation of ice on the roof. The protection guard prevents unintentional contact with the impeller.

The TFSR/TFSK models are fitted with high quality external rotor motors that provide reliable and economic ventilation.

Centrifugal fans with backward-curved blades (B-impeller) are highly efficient and are easy to clean.

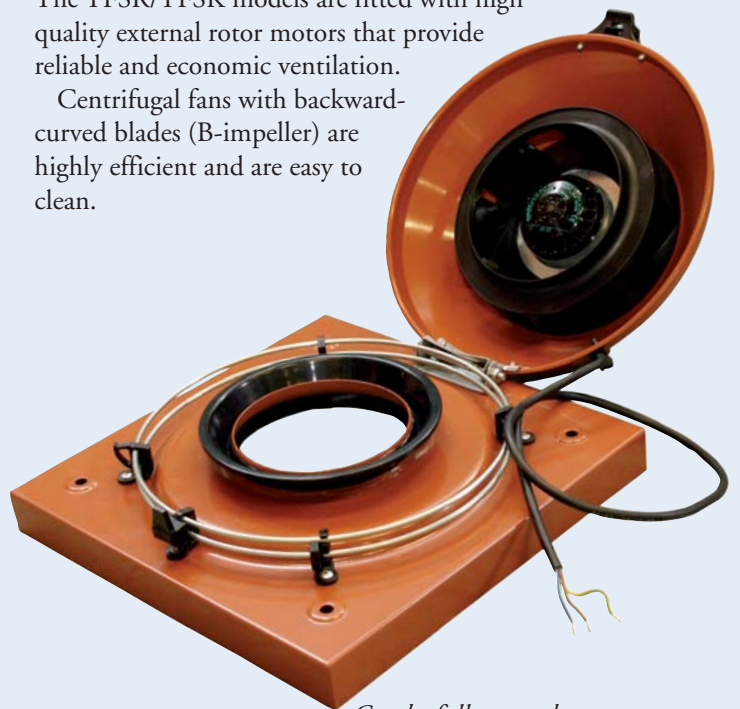

*Can be fully opened*



## TFSR

The TFSR is designed for installations with a circular connection. The fan is fitted with an isolation switch and 1 m cable for connection to a junction box.

Together with the TOS/TOB covering plate, installation is easy regardless of roof pitch. This combination makes an aesthetically attractive solution that is reliable and easy to install and maintain.

For installations that demand direct connection to a spiral duct, a sleeve connection is supplied as standard. The enclosed screws and instructions makes it an easy installation.

## TOS/TOB

The TOB/TOS are complete covering plates including junction box and 3 m cable. The covering plates are manufactured from powder-coated galvanised sheet steel in standard colours black and brick red. The spiral pipe connected to the covering plate is insulated with 30 mm mineral fibre mat. The plates come with screws for fitting to a fan.



*TFSR with the on/off switch in black*



TOB

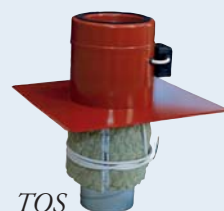

TOS

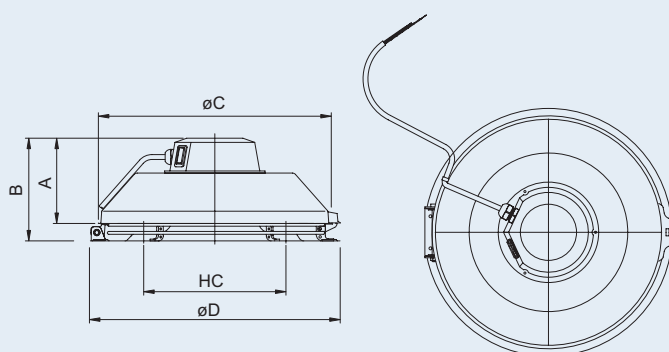

TFSR	A	B	øC	øD	HC
125 M/XL	119	144	284	315	205
160	120	145	334	380	205
200	123	160	364	439	250
315M/L	160	206	404	485	250



## TFSK

For installations with square connection, the TFSK is a suitable choice. The TFSK has a square bottom plate and is fitted with an isolation switch and 1 m cable for connection to a junction box.

For installations with high demands on sound attenuation in the duct, the TFSK in combination with the roof curb TG or the socket silencer SSD is a very good solution that is again easy to install.

## TG

The brackets make it easy to fit the TG roof curb to the roof pitch. The TG is manufactured from galvanised sheet steel and insulated with a 50 mm rock wool sheet and a perforated inner plate. The roof curb is fitted with plastic piping and conduits for electric cables.

## SSD

Socket silencer for special requirements at the inlet side. Manufactured from seawater resistant aluminium. The sound absorption at 250 Hz is in average 8 dB.

## FDS

Flats roof socket FDS is manufactured from seawater resistant aluminium and is supplied ready for assembly.

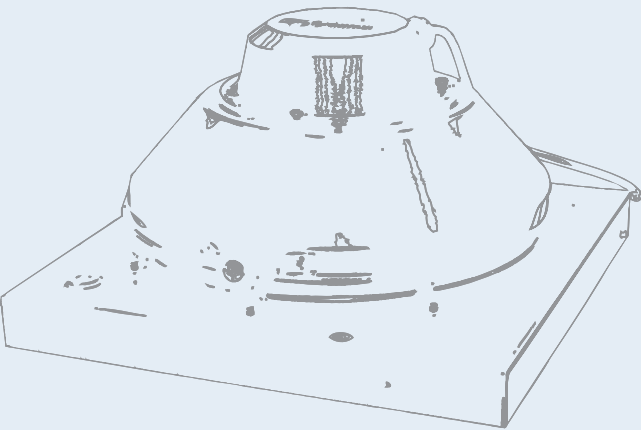

TG

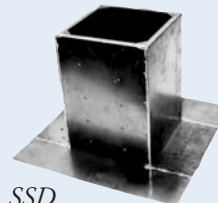

SSD

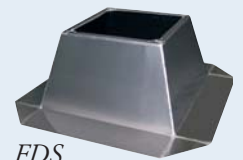

FDS

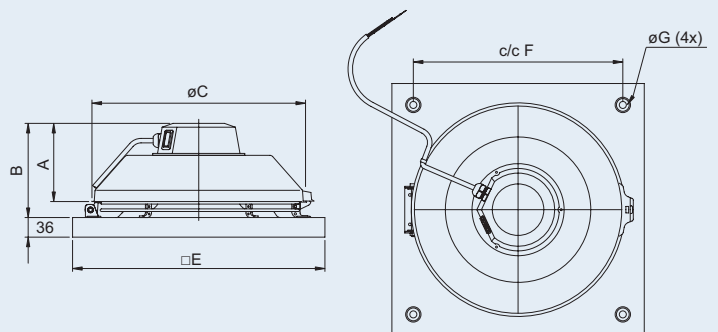

TFSK	A	B	øC	□E	c/c F	øG
125 M/XL	119	144	284	321	245	9
160	120	145	334	421	330	9
200	123	160	364	421	330	9
315M/L	160	206	404	521	450	11

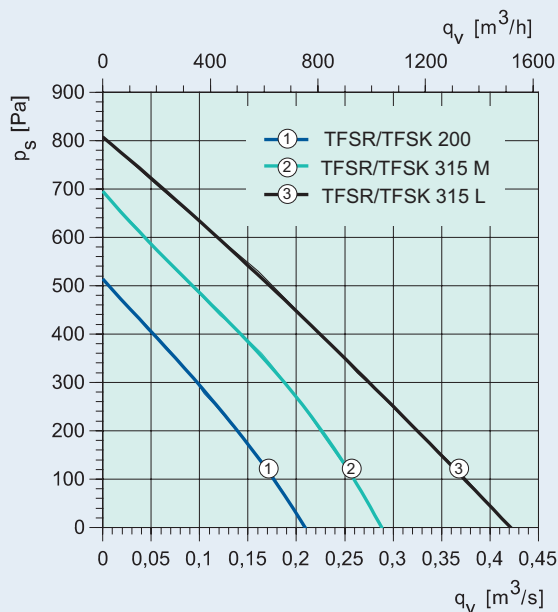
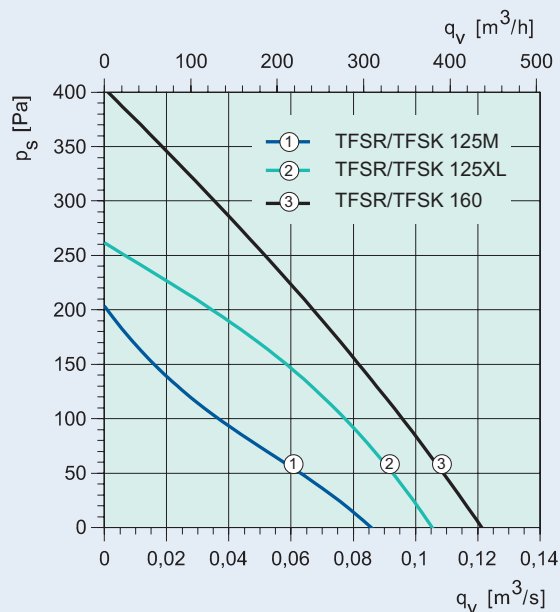

<b>TF SR/TFSK</b>		<b>125M</b>	<b>125XL</b>	<b>160</b>	<b>200</b>	<b>315 M</b>	<b>315 L</b>
Voltage/Frequency	V/50 Hz	230~	230~	230~	230~	230~	230~
Power	W	25	54	58	108	207	307
Current	A	0.13	0.26	0.26	0.47	0.90	1.35
Maximum air flow	m³/h	310	380	436	749	1040	1516
r.p.m	min <sup>-1</sup>	1965	2530	2461	2537	2575	2341
Max temp. of transported air	°C	70	40	70	62	45	58
Sound pressure level at 4/10 m*	dB(A)	31/23	41/33	44/36	48/40	51/43	55/47
Weight	kg	2.5	2.5	3,3	4,2	5,4	7
Enclosure class, motor	IP	44	44	44	44	44	44
Capacitor	µF	1,5	1,5	2	3	5	7

\*  $L_{wA} - 23/31 \text{ dB(A)} = L_{pA}$  at free field and 4/10 m distance to the fan. ( $L_{wA}$  = Sound power level,  $L_{pA}$  = Sound pressure level)



RE 1,5



REE



REE



LDC



RSK

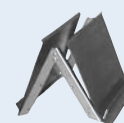

BTG



Systemair AB • 72 Cheston Road, Birmingham, B7 5EJ, United Kingdom.  
Tel 0121 322 0850 • Fax 0121 322 0859  
[www.systemair.com/en-gb/england](http://www.systemair.com/en-gb/england)

